

Q179A,B Gas Pilot Burner Assemblies

PRODUCT DATA



FEATURES

- Q179A is a gas pilot assembly with a flame electrode (rod) and ignition electrode, making it suitable for applications requiring an interrupted or intermittent electrically ignited gas pilot burner.
- Q179A1183 is an “I” port burner with an ignition electrode (spark) only.
- Q179B has only the flame electrode and is suitable for use in continuous pilot applications.
- Primary aerated type burner is equipped with stainless steel fins that provide the proper flame rod area to ground area ratio for maximum flame signal and flame stabilization.
- Stainless steel electrode(s) are mounted in ceramic insulators, which permit electrode adjustment.
- Rajah connectors facilitate disconnecting.
- Bracket permits side or end mounting.

GENERAL

Q179A,B Gas Pilot Burner Assemblies use the flame rectification principle to prove the flame. Q179A,B are used in conjunction with a suitable electronic flame safeguard control on industrial or commercial gas and gas pilot ignited oil burners.

Contents

General	1
Features	1
Ordering Information	2
Specifications	2
Installation	4
Checkout	5



SPECIFICATIONS

Model Number:

Q179A—Gas pilot assembly with ignition and flame electrodes. Use with intermittent or interrupted ignition. Ignition electrode is for use with 6,000V grounded secondary-ignition transformer. (Q179A1183 has ignition electrode [spark] only.)

Q179B—Gas pilot assembly with flame electrode (rod) only. Use with continuous pilot.

Burner:

Primary aerated. Stainless steel fins provide proper flame contact area to ground area. Flame electrode and ground bracket are furnished with each tip. Available tips are illustrated in Fig. 1, and listed in Table 1.

Mounting Means:

Bracket has holes for side mounting and two lugs for end mounting.

Type of Gas:

Natural; for LP gas, order LP orifice separately (see Accessories).

Gas Consumption:

Approximately two cu ft/hr.

Electrodes:

Stainless steel, maximum temperature 1750°F (954°C).

Electrode Insulator(s):

Ceramic.

Electrical Connector:

Rajah connector (both male and female supplied).

Approvals:

Underwriters Laboratories Inc. listed, File No. MP268;

Industrial Risk Insurers acceptable;

CSA certified, Master File No. LR-95329-1;

Factory Mutual approved;

American Gas Association certified, No. G140.401.

Mounting Dimensions:

See Fig. 2.

Maximum Temperature:

See Fig. 3.

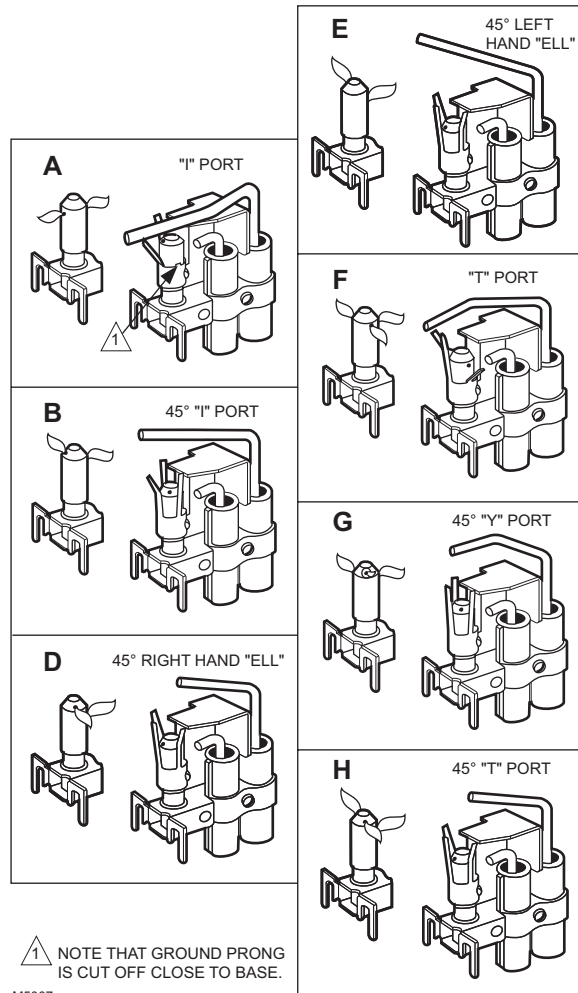

Fig. 1. Pilot tip assembly styles.

ORDERING INFORMATION

When purchasing replacement and modernization products from your TRADELINE® wholesaler or distributor, refer to the TRADELINE® Catalog or price sheets for complete ordering number, or specify:

1. Order numbr
2. Burner tip
3. Thermocouple, collar, and bracket, if desired, for Q1879B
4. High temperature cable, if required.

If you have additional questions, need further information, or would like to comment on our products or services, please write or phone:

1. Your local Honeywell Automation and Control Products Sales Office (check white pages of your phone directory).
2. Honeywell Customer Care
1885 Douglas Drive North
Minneapolis, Minnesota 55422-4386

In Canada—Honeywell Limited/Honeywell Limitée, 35 Dynamic Drive, Scarborough, Ontario M1V 4Z9.

International Sales and Service Offices in all principal cities of the world. Manufacturing in Australia, Canada, Finland, France, Germany, Japan, Mexico, Netherlands, Spain, Taiwan, United Kingdom, U.S.A.

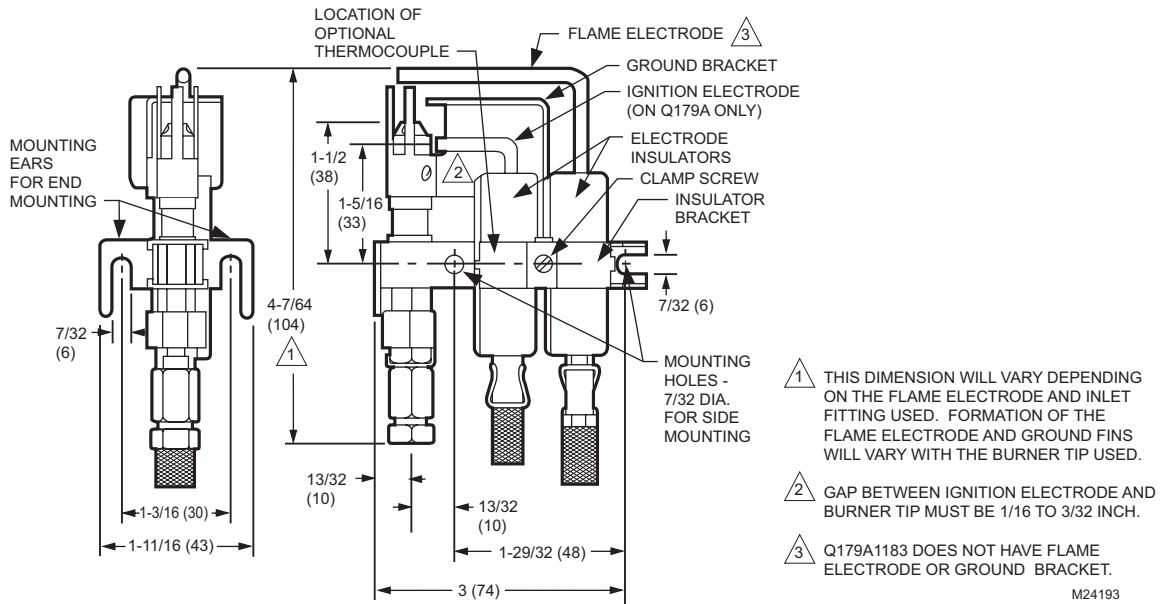

Fig. 2. Approximate mounting dimensions in in. (mm) and arrangement of parts.

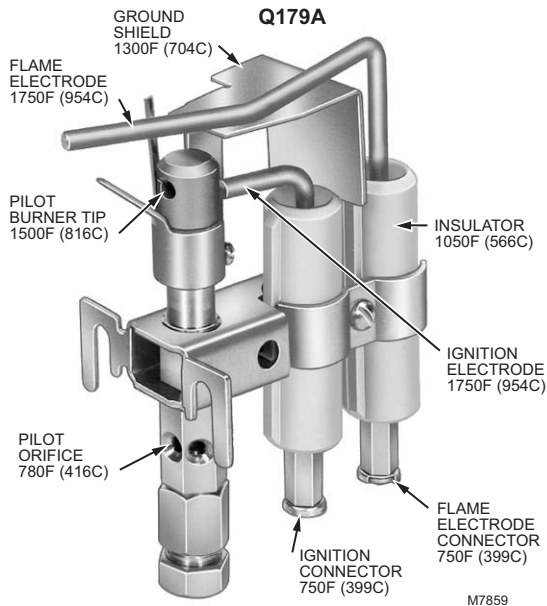

Fig. 3. Component maximum temperature ratings.

Inlet Fittings:

1/4 inch compression coupling factory-installed on all models.

Replacement Parts (See Table 1):

- 37356 Rajah Connector—for ignition electrode.
- 104312 Rajah Connector—for flame electrode.
- 133445A Ignition Electrode and Insulator Assembly.

Accessories:

- High temperature (higher than 125°F [52°C]) cable:
- Flame Rod Leadwire—part no. R1298020 (specify length) rated at 400°F (204°C).
- Ignition Leadwire—part no. R1061012 (specify length), rated at 350°F (177°C).
- High Tension Cable—part no. R1239001 (specify length), rated at 220°F (104°C).

Table 1. Additional Q179A, B Replacement Parts

Assembly Tip Style	Tip	Ground and Ground Shield ^a	Orifice		Flame Rod and Insulator Assembly
			Natural Gas	LP Gas	
I	105063A	102464A	395390-25 ^b	395390-13 ^c	133448A
45° I	105064A	102464B	395390-25 ^b		133450A
45° RH	105066A	120464D	395390-25 ^b		133452A
45° LH	105067A	102464D	395390-25 ^b		133444A
T	105068A	102464F	395390-28 ^d		133451A
45° Y	105069A	102464C	395390-28 ^d		133446A
45° T	105070A	102464H	395390-28 ^d		133452A
Large I	121831A	102464A	395390-25 ^b		133448A

^a On some ground areas, one or more prongs were intentionally removed at the factory.

^b Orifice 0.025 in. (0.635 mm) diameter.

^c Orifice 0.0130 in. (0.330 mm) diameter (order separately).

^d Orifice 0.028 in. (0.711 mm) diameter.

INSTALLATION

When Installing this Product...

1. Read these instructions carefully. Failure to follow them could damage the product or cause a hazardous condition.
2. Check the ratings given in the instructions and on the product to make sure the product is suitable for your application.
3. Installer must be a trained, experienced, flame safeguard control technician.
4. After installation is complete, check out product operation as provided in these instructions.

Follow instructions provided by burner manufacturer if available. If no instructions are furnished, use the following recommendations.

Mounting

The Q179 has two mounting ears at the burner and two mounting holes in the bracket (see Fig. 2). If the mounting holes in the bracket are used, it may be necessary to break off one of the mounting ears so that the bracket fits flush with the burner.

All models are supplied with a factory-installed 1/4 inch compression coupling inlet fitting. When a fitting is used, remove the compression nut and install the new fitting.

Gas Pressure Regulation

Use a pressure regulator in the line supplying the Q179 pilot. Adjust the regulator for a maximum inlet gas pressure of eight inches water column. The minimum inlet gas pressure must be two inches water column to assure reliable lightoff of the main flame.

Install the Q179A,B

Install the pilot assembly so the pilot flame has full contact with the gas stream from the main burner heads or jets. Mount the flame electrode just inside the junction of the main and pilot flame to prove both flames. Mount the pilot so that it fires in the same direction as the draft at the mounting point, rather than where the draft is at right angles to flame travel. Keep the pilot burner below or behind the main burner so that the burner frame and refractory will help protect the pilot from radiant heat. Locating the pilot in the secondary air stream will also provide considerable cooling. The primary air adjustment must be accessible and outside the high temperature area.

Do Not Install the Q179A,B—

- Where ambient temperatures exceed those specified in Fig. 3.
- Where excessive draft turbulence can deflect the pilot flame away from the main burner or flame electrode.
- Where the ignition electrode is within arcing distance of any metal other than the pilot burner head.
- Where the flame electrode contacts any metal part of the installation.
- Where the flame electrode is closer than one inch from a radiant refractory.

WIRING



CAUTION

Disconnect power supply to prevent electrical shock and equipment damage. More than one disconnect may be involved. Wiring must conform to local codes and ordinances.

Rajah connectors are furnished for making connections to the ignition and flame electrodes. The ignition electrode (A models only) takes a receptacle connector. The flame electrode (both A and B models) takes a plug connector and has a snap-action spring terminal.

Use high tension wire, of a type found acceptable by a nationally recognized testing agency, for the wiring to the ignition electrode (Q179A). High tension wires should be rated electrically equivalent to type GTO-10 and should have temperature and humidity characteristics adequate for the application. If the ignition lead is exposed to temperatures above 125°F (52°C), use Honeywell R1061012 Ignition Cable rated at 350°F (177°C) or equivalent. For ignition installations in a contaminated environment, use Honeywell R1239001 High Tension Cable rated at 220°F (104°C) or equivalent.

For wiring between the F terminal of the relay and the flame electrode, use wire with moisture-resistant insulation. Number 14 single-conductor TW wire is adequate; however, those portions of the leadwire exposed to temperatures over 125°F (52°C) should also be heat resistant. For both heat and moisture-resistant applications, use part no. R1298020 Flame Rod Leadwire rated at 400°F (204°C) continuous duty or equivalent.

Run a ground wire from the pilot burner to the relay to assure a continuous, unchanging ground.

For detailed wiring diagrams, see the Instructions packed with the flame safeguard control.

CHECKOUT

CAUTION

Check to ensure the main valve opens only when the pilot flame is strong enough to ignite the main burner. Perform the pilot turn-down test as described in the Honeywell Flame Safeguard Control instructions.

The proper pilot burner orifice must be selected for the gas being used (natural, LP gas) so that the pilot burns with a medium hard flame. This type of flame provides the maximum flame signal.

The flame safeguard control relay will chatter if excess secondary air velocity or a severe draft condition causes the pilot flame to make intermittent contact with the flame electrode (rod) or grounding bracket.

The performance of the pilot assembly can be determined by measuring the flame signal developed with the pilot operating. The flame signal (current/voltage) measurement requires the use of an appropriate volt-ohmmeter.

Most existing Honeywell Flame Safeguard Controls incorporate a flame current jack in the control plug-in amplifier or in the control itself. The flame current measurement can be made with a Honeywell W136A Test Meter, which has a 0 to 25 microampere dc scale (see Fig. 4). With the W136A selector switch positioned to the 0 to 25 microampere scale, connect the meter leads to the two ends of the meter connector plug, positive (red, +) to positive, negative (black, -) to negative. The Meter Connector Plug part no. 196146 is provided with the W136A Meter. If a W136A Meter or connector plug is not

available, a dc ammeter with a 0 to 25 microampere scale can be wired in series with the F lead of the flame detector circuit. A minimum flame current of 2.0 microamperes is considered acceptable.

The Honeywell BCS 7700 and 7800 SERIES Flame Safeguard Control flame signals are measured in dc volts. A 20,000 volt/ohm meter with a 0 to 5 or 10 Vdc scale is recommended for measuring the flame signal of BCS 7700 controls while a one megohm/volt meter is recommended for 7800 SERIES controls. The flame signal voltages are measured as illustrated in Fig. 5 and 6.

The minimum acceptable flame signal voltage for the BCS 7700 controls is 2.2 Vdc (maximum expected is 4.98 Vdc).

The minimum acceptable flame signal voltage for the 7800 SERIES controls is 1.25 Vdc (maximum expected is 5.0 Vdc).

If the flame signal is less than the minimum acceptable for the Honeywell Flame Safeguard Control used, adjust the flame electrode (rod) to increase the flame signal to at least the minimum acceptable level by loosening the clamp screw and turning the electrode (rod) slightly to the right or left as required. After the flame electrode (rod) is adjusted, check the gap between the ignition electrode and burner tip (Q179A). The gap must be between 1/16 and 3/32 inch.

Perform the pilot turndown test as described in the Flame Safeguard Control Instructions to ensure the pilot flame is adequate to ignite the main burner.

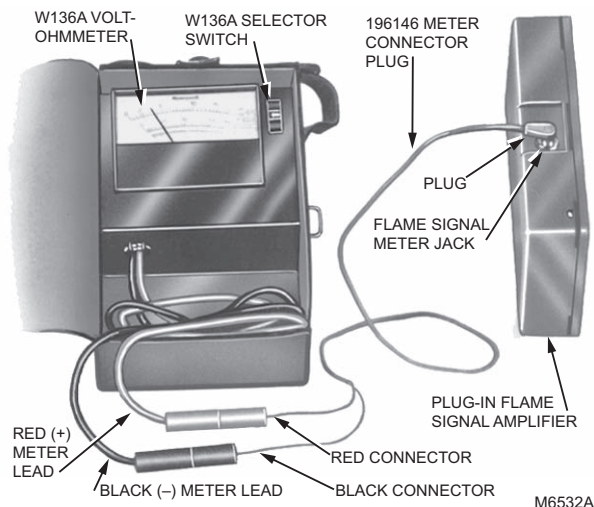

Fig. 4. Measuring microamp flame signal.

Pilot Turndown Test

If the flame rod is used to prove a pilot flame before the main fuel valve(s) can be opened, perform a pilot turndown test. Follow the procedures in the Instructions for the appropriate Flame Safeguard Control, and in the burner manufacturer's instructions.

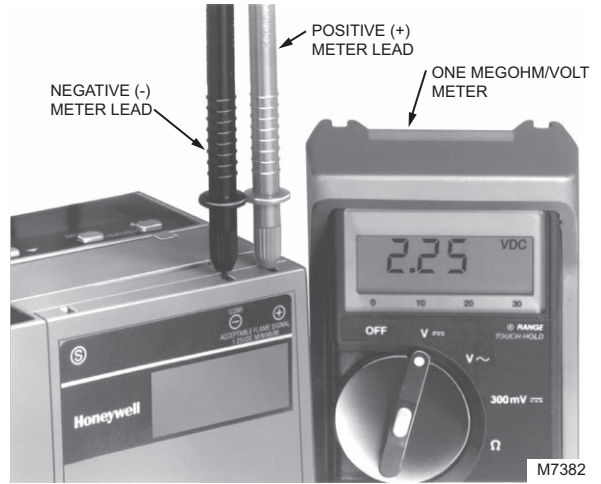
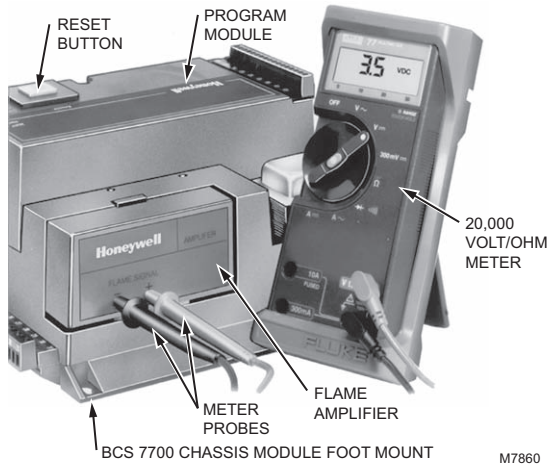

Fig. 5. Measuring BCS 7700 Control flame signal voltage.

Fig. 6. Measuring 7800 SERIES Control flame signal voltage.

Automation and Control Solutions

Honeywell International Inc.
1985 Douglas Drive North
Golden Valley, MN 55422
customer.honeywell.com

Honeywell Limited-Honeywell Limitée
35 Dynamic Drive
Scarborough, Ontario M1V 4Z9

® U.S. Registered Trademark
© 2005 Honeywell International Inc.
60-2032—4 M.S. Rev. 11-05



Printed in U.S.A. on recycled
paper containing at least 10%
post-consumer paper fibers.

Honeywell