



NRF / NBF / SSF Circulator

Installation, Operation & Service Instructions

INSTALLER: PLEASE LEAVE THIS MANUAL FOR THE OWNER'S USE.

NOTE: Bell & Gossett recommends Bronze Booster Pumps be used for pumping potable water.



SAFETY INSTRUCTIONS

This safety alert symbol will be used in this manual and on the pump Safety Instruction decal to draw attention to safety related instructions. When used, the safety alert symbol means **ATTENTION! BECOME ALERT! YOUR SAFETY IS INVOLVED! FAILURE TO FOLLOW THE INSTRUCTIONS MAY RESULT IN A SAFETY HAZARD.**

Your NRF/NBF/SSF Booster Pump should have the warning/caution label displayed to the right (Fig. 1) on the pump conduit box. If this warning and caution label is missing or illegible, contact your local B&G Representative for a replacement.

<p>▲ WARNING</p> <p>BEFORE INSTALLING, USING OR SERVICING THIS PRODUCT, READ THE INSTRUCTIONS. TO REDUCE RISK OF ELECTRICAL SHOCK SEE INSTRUCTIONS FOR PROPER INSTALLATION.</p>
<p>▲ CAUTION</p> <p>FOR SUPPLY CONNECTIONS USE WIRE SUITABLE FOR AT LEAST 90°C. USE COPPER CONDUCTORS ONLY. EMPLOYER DES FILS D'ALIMENTATION ADEQUATS POUR 90°C. FOR INDOOR USE ONLY. EMPLOYER UNIQUEMENT A L'INTERIEUR.</p>

FIG. 1

DESCRIPTION

The Model NRF/NBF/SSF Circulator Pump features system liquid lubricated bearings, non-overloading permanent split capacitor motor with impedance protection and quiet operation.

PUMP APPLICATION

The Model NRF/NBF/SSF Booster Pump may be used for water circulating applications in hydronic and solar systems.

OPERATIONAL LIMITS

These pumps are designed to pump liquids compatible with their iron or bronze body constructions.

Maximum Operating Pressure: 150 PSI (10 bars)

Maximum Operating Temperature:

NRF-22 & NRF-9F/LW, 240°F (115° C)

NBF Pumps (except NBF-33), 230°F (110°C)

NRF-33 & NBF-33, 225°F (107°C)

SSF Pumps, 230°F (110°C)

Electrical Rating: 115V, 60Hz, 1Ø; 220V, 60Hz, 1Ø;

220V, 50Hz, 1Ø; 230V, 60Hz, 1Ø

If your NBF pump is equipped with a sweat connected pump body, the maximum operating pressure is limited to 150 PSI (10 bars) or a lower value determined by the type of solder used and pressure/temperature limitations listed below:

Do not exceed these values.

(Solder type limits per ASTM STD. B16.18-1978)

PUMP BODY	TYPE OF SOLDER	MAXIMUM LIMITATIONS	
		PRESSURE PSI	TEMPERATURE °F
SWEAT	95-5	300	200
	TIN-	250	225
	ANTIMONY	200	250



WARNING:

Damage to the pump or failure of solder sealing joints may occur if these operational limits are exceeded. This can result in water leakage. Failure to follow this instruction could cause serious personal injury and/or property damage.

SAFETY REQUIREMENTS

MECHANICAL SAFETY



WARNING: EXCESSIVE SYSTEM PRESSURE HAZARD

The maximum working pressure of the pump is listed on the nameplate – DO NOT EXCEED THIS PRESSURE. Failure to follow these instructions could result in serious personal injury, death and/or property damage.



WARNING: EXCESSIVE PRESSURE HAZARD VOLUMETRIC EXPANSION

The heating of water and other fluids causes volumetric expansion. The associated forces may cause failure of system components and the release of high temperature fluids. This can be prevented by installing properly sized and located compression tanks and pressure relief valves. Failure to follow these instructions could result in serious personal injury, death and/or property damage.

THERMAL SAFETY



WARNING: EXTREME TEMPERATURE HAZARD

If the pump, motor or piping are operating at extremely high or low temperature, guarding or insulation is required. Failure to follow these instructions could result in serious personal injury, death and/or property damage.

ELECTRICAL SAFETY



WARNING: ELECTRICAL SHOCK HAZARD

Electrical connections are to be made by a qualified electrician in accordance with all applicable codes, ordinances and good practices. Failure to follow these instructions could result in serious personal injury, death and/or property damage.



WARNING: ELECTRICAL GROUNDING HAZARD

Adequate electrical grounding is required for the safe operation of B&G Pumps. The use of grounded metal conduit assures this requirement. If the means of connection to the supply – connection box (wiring compartment) is other than grounded metal conduit, ground the pump back to the service. Use a copper conductor at least the size of the circuit connectors supplying the pump. Connect the ground wire to the green grounding screw in the wiring compartment. Failure to follow these instructions could result in serious personal injury death and/or property damage.

This pump is for indoor use only.

REMOVAL OF PUMP FROM EXISTING SYSTEM FOR REPLACEMENT



WARNING: ELECTRICAL SHOCK HAZARD

Disconnect and lockout the power before servicing. Failure to follow these instructions could result in serious personal injury or death.

1. Close the valves on the suction and discharge sides of the pump. (If no valves have been installed, it may be necessary to drain the system.)



WARNING: HOT WATER HAZARD

Before draining the system, allow water to cool to at least 100°F, open the drain valve (take precautions against water damage) and leave the drain valve open until servicing is complete. Failure to follow these instructions could result in serious personal injury, death and/or property damage.



WARNING: ELECTRICAL SHOCK HAZARD

Be certain the electrical power is not present at the motor leads before continuing. Failure to follow these instructions could result in serious personal injury or death

2. Loosen the conduit box cover screw and remove the cover.
3. Disconnect the electrical supply lines to the pump.



WARNING: HIGH PRESSURE HAZARD

Pressure may be present in the pump body. This pressure can be relieved by loosening the flange bolts and shifting the pump assembly slightly to allow the pressurized water to escape. Failure to follow these instructions could result in serious personal injury or death.

4. Remove the flange nuts and bolts or loosen the union ring nuts. Then remove the pump from the piping.

PUMP INSTALLATION

Locate the pump so there is sufficient room for inspection, maintenance and service. Bell & Gossett recommends the installation of service valves on the suction and discharge of all circulators to facilitate servicing or replacement of the circulator without draining the system.

CAUTION: The use of Teflon® impregnated pipe compound and Teflon® tape on pipe threads provides lubricity which can lead to overtightening and breakage. Do not overtighten. Failure to follow this instruction can result in moderate personal injury from hot water and/or property damage.

Install suction and discharge flanges or union connectors on the pipe ends. The use of Teflon®* tape sealer or a high quality thread sealant is recommended.

Be sure to minimize any pipe-strain on the pump. Support the suction and discharge piping by the use of pipe hangers near the pump. Line up the vertical and horizontal piping so that the bolt-holes in the pump flanges match the bolt-holes in the pipe flanges. If union connections are used, line up the pump threads with union tail pieces. **DO NOT ATTEMPT TO SPRING THE SUCTION OR DISCHARGE LINES IN POSITION. THIS MAY RESULT IN UNWANTED STRESS IN THE PUMP BODY, FLANGE CONNECTIONS AND PIPING.** The code for Pressure Piping (ANSI B31.1) lists many types of supports available for various applications.

Bell & Gossett flange/union gaskets must be installed between the NRF/NBF/SSF pump body flanges and the suction and discharge pipe flanges/union tail pieces. Use 7/16" diameter x 1 1/2" long cap screw and matching nut to connect the pump to the flanges.

WARNING: HOT WATER HAZARD
When disassembling a gasketed joint, always use a new gasket upon reassembly. **NEVER RE-USE OLD GASKETS.** Failure to follow these instructions could result in serious personal injury, death and/or property damage.

Apply torque in even increments to both flange bolts until a value of 115 in-lbs. is reached. Both the suction and discharge flange bolts must be torqued in this manner.

If your NBF pump is equipped with a sweat connected pump body, see the following instructions:

1. Use a torch with a sharp pointed flame.
2. Clean tube ends and pump connections thoroughly.
3. Use 95-5 (Tin-Antimony); 50-50 or 60-40 (Tin-Lead) solders only, and a good grade of flux.

CAUTION:
Heat associated with the use of silver solder may damage a pump voiding the warranty. Do not use silver solder. Failure to follow these instructions could result in property damage and/or moderate personal injury.

CAUTION:
Excessive use of solder in a vertical installation may result in damage to the pump impeller. Do not use excessive flux. Failure to follow these instructions could result in property damage and/or moderate personal injury.

4. When sweating the joints, first wrap the pump body with a cool wet rag, then direct the flame with care to avoid subjecting the pump to excessive heat.
5. Check soldered connections for leaks. If resoldering is required, take care to avoid subjecting the pump to excessive heat.

WARNING: WATER LEAKAGE HAZARD
To prevent leakage, make certain that the flange bolts or ring nuts have been adequately tightened and that the solder connections do not leak. Failure to follow these instructions could result in serious personal injury, death and/or property damage.

MODE OF DISCHARGE

The Model NRF/NBF/SSF Circulator can be installed to discharge up or down, horizontally, left or right, but the motor shaft must remain in the horizontal position, the arrow on the body must point in the direction of the flow, the conduit box must be positioned on the top or to the side of the motor housing (see figure 2). If the conduit box position must be changed, it is best to do so before installation. However, if the pump is already installed, see the section titled "REMOVAL OF PUMP FROM EXISTING SYSTEM FOR REPLACEMENT" before proceeding.

CAUTION:
Make sure the power is turned off before placing anything inside the discharge opening to move the impeller.

TO CHANGE THE CONDUIT POSITION

1. Remove the four (4) 1/4-20 Allen screws (3/16 wrench) while supporting the motor assembly.
2. Remove the motor assembly from the pump body and rotate it to the desired position (see figure 2).
3. Replace the Allen screws and tighten evenly in a diagonal method to 60 in-lbs.
4. Check to see that the impeller turns freely. Insert your finger in the discharge port of the pump body (the arrow on the pump body points in the direction of the discharge) until you can feel the impeller and rotate it with your fingertip. If the impeller does not turn easily, repeat the disassembly/reassembly process.

*Teflon® is a registered trademark of E.I. DuPont de Nemours and Company.

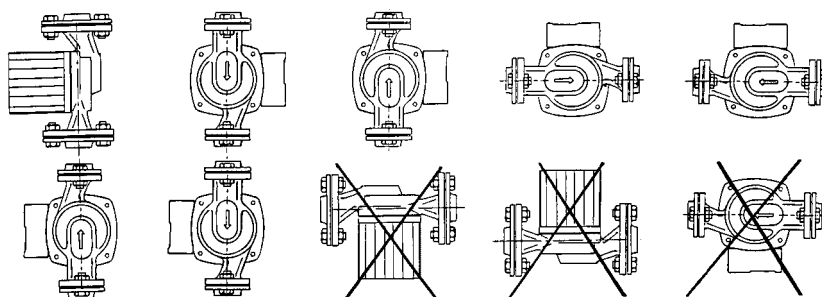

FIG. 2

⚠ WARNING: ELECTRICAL SHOCK HAZARD
 Disconnect and lock out the power before making electrical connections. Failure to follow these instructions could result in serious personal injury or death.

⚠ WARNING: ELECTRICAL SHOCK HAZARD
 Be certain that all connections are secure and the conduit box cover is closed before electrical power is connected. Failure to follow these instructions could result in serious personal injury, death and/or property damage.

WIRING INSTRUCTIONS

- A. Loosen the screw securing the conduit box cover (wiring compartment), and remove the screw & cover.
- B. Attach the appropriate size connector to the hole in the side of the conduit box.
- C. Using a minimum size of 14 AWG copper electrical wire (refer to your local code for wiring restrictions), wire the motor to a single phase power source that matches the electrical rating on the pump nameplate. See Fig. 3. Use the size of electrical wire as dictated by local code.
- D. Connect the ground wire to the inside of the conduit box with one of the green screws provided inside the box. See Fig. 4.

NOTE: Electrical supply and grounding wires must be suitable for at least 90°C (194°F).

NOTE: Model NRF/NBF/SSF Circulators are impedance protected and do not require external overload protection.

TYPICAL WIRING INSTALLATION SCHEMATIC
1Ø POWER SOURCE

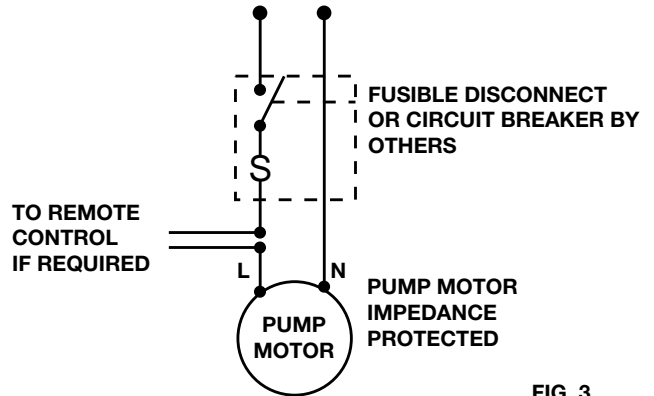

FIG. 3

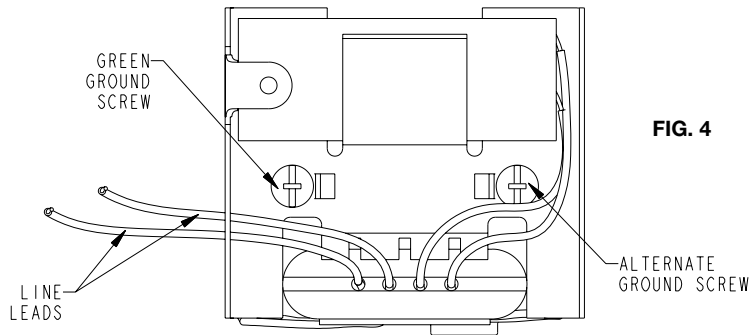

FIG. 4

SYSTEM PREPARATION

Prior to pump start-up, closed heating and cooling systems should be cleaned, drained, and refilled with clean water. The system fluid pH must be maintained between 7 and 9.

START-UP

Do not start pump until the system has been filled and vented. Air should be vented from the system by means of an air vent located at a high point in the system. The system must be completely vented prior to pump operation. Do not run NRF/NBF/SSF circulators dry. Pump operation without water circulation could result in pump and motor damage.

⚠ WARNING: HOT WATER LEAKAGE HAZARD
 Pressurize the body slowly while checking for leaks at all joints with gaskets or solder connections. Failure to follow these instructions could result in serious personal injury and/or property damage.

PERIODIC INSPECTION

Bell & Gossett NRF/NBF/SSF Circulators are designed to provide years of trouble free service. It is recommended that periodic inspections be made to check for potential problems with the pump. If any leakage or evidence of leakage is present, repair or replace the unit.